



-proof

DUK

DITTELBACH UND KERZLER

Conveyor Belt Misalignment Switch

LHPE-xx/x-L50-EX

**For use in zone 22
ATEX approval**

Tough, reliable, and quality engineered are the outstanding features of this switch. Even under most arduous environments they withstand corrosive atmospheres, heavy duty service and mechanical impacts.

They comply with the demands of the standard EN 60079-31. By their marking with Ex II 3D Ex tc IIIC T90°C Dc they are approved for use in areas under conductive dust. They comply to all other applicable European standards and are marked with the CE-mark.

Misalignment switches should be installed pairwise, left and right of the edges of the conveyor belt. In case that the belt should misalign from the given track, one roller lever of this pair of switches will be touched by the edge of the belt and displaced against the resetting force of an internal spring. If the increasing displacement oversteps a factory setted threshold the snap action contacts are operated. The maximum displacement angle is 75°. Optional is a 2-stage characteristic, first stage at small misalignment for pre-warning and the second stage for cutting off. If the amount of misalignment will be reduced reset happens automatically.

Optional is a latching version holding the contacts in operated position with manual reset.

Stepless adjustability of the actuation lever on the switch shaft allows easy adjustment of the clearance between lever and the edge of the belt.

Secure opening of each NC-contact is guaranteed by the direct opening system (positive drive for each NC-contact). For decreasing the electrical transition resistance between the contact surfaces all contacts perform a self-cleaning action with each operation. The contacts are made of silver and get optionally a gold surface. For lowest tensions and currents the optional gold contacts are recommended.

The actuation lever of this switch is made of corrosion-free materials: Hub, shaft, roller and the 2 ball bearings are of stainless steel.

The large diameter of the roller (50mm) facilitates the service on conveyors with high belt speeds.

2 different materials for the switch enclosures (same dimensions) make further selection necessary: On one hand the housing of cast iron: Most stable, normal resistant against corrosion (but much better than aluminium), costly in production, double 2-component coated. On the other hand the economic enclosure of thick walled, special for use in EX-areas permissible fibre glass reinforced polyester with reduced electrical surface resistivity: Same stability as cast iron and indisputable corrosion-resistant against saline water as well as most chemicals.



- **Corrosion-resistant Polyester enclosure (BMC)**
or
Cast iron housing
- **50mm diameter roller**
- **IP67**
- **Up to 4 contacts NC plus 4 NO**
- **Direct opening snap action contacts**
- **Silver- or gold contacts**
- **Stepless adjustable space between roller and the edge of the belt**
- **Stainless steel ball bearing**



DITTELBACH UND KERZLER GmbH & Co. KG Talstrasse 27 D-35394 Giessen

Tel.: +49 641 97224-0 Fax: +49 641 97224-22 web: DUK.eu e-mail: info@DUK.eu

- proof Conveyor Belt Misalignment Switch LHPE-xx/x-L50-EX



Technical data

Conforms to standards	EN 60079-31 EN 60947-5-5, EN 60529, EN 60204
Switches are marked	 II 3D Ex tc IIIC T90°C Dc
Contacts	Up to 4 NC plus 4 NO, self-cleaning surfaces
Thermic Currents I_{th}	Silver contacts: AC: 400V 6A, 230V 8A DC: 24V 10A, 80V 3A
Minimum current	Gold: 1mA @ 6VDC
Utilization categorie	Silver AC-15 230V 1A, DC-13 110V 0,5A Gold AC-12 230V 250mA, DC-12 110V 250mA
Cable inlets	2 x M25 threads
Protection	IP 67
Ambient temperature T_{amb}	-40°C up to 80°C (on request -55°C)
Max. temperature of surface of housing	90°C
Material of housing	LHP... BMC, fibre-glass reinforced polyester LHM... cast iron
Colour of housing	LHP... black, LHM... yellow, optional other
Weight	2,9 kg (LHP...), 7 kg (LHM...)
Mounting	2 slotted holes for M10 screws (max. 11mm)
Roller lever	stainless steel double-ball beared, stepless adjustable on the switch shaft

Selection table

Type	Contacts		Warning contact		Latching	Contacts
	NC	NO	NC	NO		
LHPE-10/1-L50-EX	1	1				made of silver
LHPE-18/1-L50-EX	2					made of silver
LHPEw-10/1-L50-EX	1	1			yes	made of silver
LHPEw-18/1-L50-EX	2				yes	made of silver
LHPE-10/2-L50V-EX	1	1	1	1		made of silver
LHPEw-10/2-L50V-EX	1	1	1	1	yes	made of silver
LHP-10/2L50-EX	2	2				made of silver
LHPw-10/2-L50-EX	2	2			yes	made of silver
LHP-10/3-L50V-EX	2	2	1	1		made of silver
LHPw-10/3-L50V-EX	2	2	1	1	yes	made of silver
LHP-10/3-L50-EX	3	3				made of silver
LHPw-10/3-L50-EX	3	3			yes	made of silver
LHP-10/4-L50V-EX	3	3	1	1		made of silver
LHPw-10/4EX-L50V	3	3	1	1	yes	made of silver
LHP-10/4-L50-EX	4	4				made of silver
LHPw-10/4-L50-EX	4	4			yes	made of silver
LHPE-13/1-L50-EX	1	1				gold surface
LHPE-19/1-L50-EX	2					gold surface
LHPEw-13/1-L50-EX	1	1			yes	gold surface
LHPEw-19/1-L50-EX	2				yes	gold surface
LHPE-13/2-L50V-EX	1	1	1	1		gold surface
LHPEw-13/2-L50V-EX	1	1	1	1	yes	gold surface
LHP-13/2-L50-EX	2	2				gold surface
LHPw-13/2-L50-EX	2	2			yes	gold surface
LHP-13/3-L50V-EX	2	2	1	1		gold surface
LHPw-13/3EX-L50V	2	2	1	1	yes	gold surface
LHP-13/3-L50-EX	3	3				gold surface
LHPw-13/3-L50-EX	3	3			yes	gold surface
LHP-13/4-L50V-EX	3	3	1	1		gold surface
LHPw-13/4-L50V-EX	3	3	1	1	yes	gold surface
LHP-13/4-L50-EX	4	4				gold surface
LHPw-13/4-L50-EX	4	4			yes	gold surface

Cast iron housing All types are available also in cast iron housing, use type figures LHM... instead of LHP...e.g.. LHME-10/2-L50V-EX

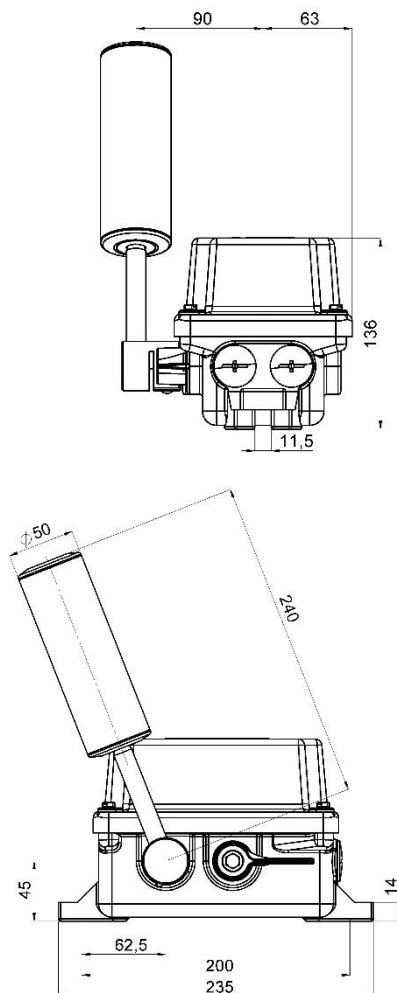

DITTELBACH UND KERZLER GmbH & Co. KG Talstrasse 27 D-35394 Giessen

Tel.: +49 641 97224-0 Fax: +49 641 97224-22 web: DUK.eu e-mail: info@DUK.eu