



-Proof Lever Limit Switch



DITTELBACH UND KERZLER

Position Switch

LHP_{xx-xx/x-R-EX}

For use in zone 22
ATEX approval



- **Snap action contacts**
- **Direct opening**
- **2 x M25 cable entries**
- **Fibre Glass Reinforced Polyester enclosure**
optional **Cast Iron**
- **IP 67**



Lever Limit Switches are for cutting off on limit positions or for signalling at reached positions of linear or swivelling movements.

Tough, reliable, and quality engineered are the outstanding features of this type of switch. Even under most arduous environments they withstand corrosive atmospheres, heavy duty service and mechanical impacts.

They comply with the demands of the new European standard EN 60079-31. By their certification and their marking with II 3D Ex tc IIIC T90°C Dc they are approved for use in areas under conductive dust. They comply also to all other applicable European standards and are marked with the CE-mark.

The actuation lever of these switches is pressed by an internal spring into its middle, neutral position. This actuation lever can be displaced by an actuation bar or cam clockwise as well as anti-clockwise out of neutral position. When displaced, the tripping of the contacts happens with snap-action and with direct opening (positive drive). When leaving the area of cam or actuation bar, the lever will turn back into its neutral position by the force of the internal spring and resetting happens with snap action. Optional is the latching in actuated position for manual reset.

These switches can be equipped with up to 4 micro switches, each incorporating either 1 NC-contact plus 1 NO or 2 NC-contacts, both types with self-cleaning surfaces reducing the electrical transition resistance. The contact surfaces are of silver. Optional is a gold plating, recommendable at lowest tensions and currents.

The micro switches are tripped either independent on the direction of the actuation lever displacement (clockwise lever operation acts on the same microswitches as anti-clockwise) or tripped depending on the direction (for sensing the direction of displacement).

The lever can be mounted in 4 positions (4 x 90° by featherkey connection) on the shaft. The maximum possible displacement angle of the roller lever is 75°. The stable roller of the actuation lever is made of best carbonated polyamide and is sleeve-bearred on the stainless steel axle.

2 different materials for the switch enclosures (same dimensions) make further selection necessary: On one hand the housing of cast iron: Most stable, normal resistant against corrosion (but much better than aluminium), costly in production, double 2-component coated. On the other hand the economic enclosure of thick walled, special for use in EX-areas permissible fibre glass reinforced polyester with reduced electrical surface resistivity: Same stability as cast iron and indisputable corrosion-resistant against saline water as well as most chemicals.



DITTELBACH UND KERZLER GmbH & Co. KG Talstrasse 27 D-35394 Giessen

Tel.: +49 641 97224-0 Fax: +49 641 97224-22 web: DUK.eu e-mail: info@DUK.eu

Ex-proof Lever Limit Switch LHP_{xx-xx/x-R-EX}

Technical data

Conforms to standards	EN 60079-31, EN 60947-5-1, with latching EN 60947-5-5, EN 60529, EN 60204
Switches are marked	Ex II 3D Ex tc IIIC T90°C Dc
I_{therm}	silver contacts : max 400VAC 6A, 230VAC 8A, cos phi=1 24VDC 10A, 80VDC 3A (0ms)
Utilization category	silver contacts: AC-15 230V 1A, DC-13 110V 0,5A gold contacts: AC-12 230V 250mA, DC-12 110V 250mA
Minimum current	gold contacts: 1mA@ 6VDC
Cable inlets	2 x M25 threads
Protection	IP 67
Ambient temperature T_{amb}	-40°C up to 80°C (on request -55°)
Max. temperature of surface of housing	90°C
Material of housing	LHP... fibre-glass reinforced polyester (BMC), LHM... cast iron
Actuation lever	Aluminium, roller made of polyamide
Colour of housing	LHP.... black, LHM... yellow optional other
Weight	2,3 kg (LHP...), 7 kg (LHM...)
Mounting	2 slotted feet for M10 screws

Values for the calculation of SIL or PL according EN 13849 and IEC 61508

B10	with latching 80000 cycles
	without latching depending on the actuation speed
	= 1.5m/s 200000 cycles
	< 1.5m/s up to 500000 cycles

typ. share of dangerous faults 0.5

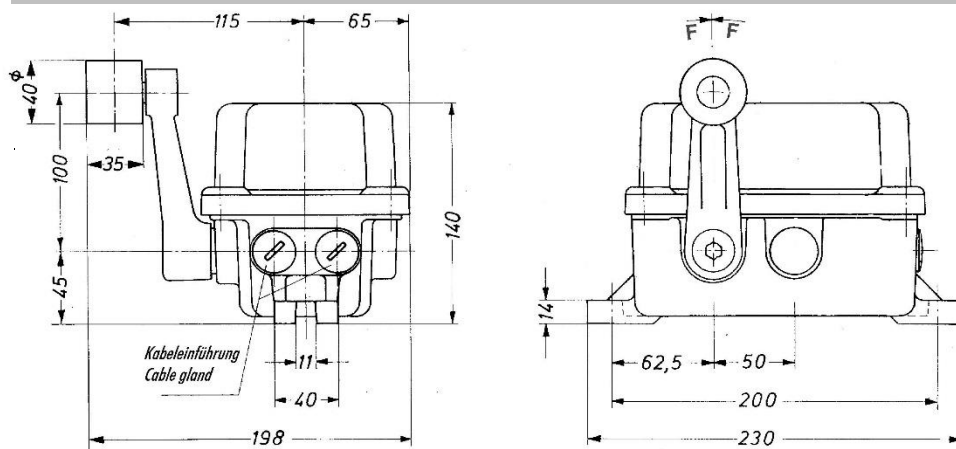

Selection table

Enclosure made of fibre glass reinforced polyester, contacts of silver, no latching

Type	Contacts		latching	operation angle	max. angle
	unidirectional	only LH only RH			
LHPE-10/1-R-EX	1NC+1NO		non	15°	75°
LHPE-18/1-R-EX	2NC		non	15°	75°
LHPE-10/2-R-EX	2NC+2NO		non	15°	75°
LHPE-18/2-R-EX	4NC		non	15°	75°
LHP-10/3-R-EX	3NC+3NO		non	30°	75°
LHP-10/4-R-EX	4NC+4NO		non	30°	75°
LHPE-10/2-R2-EX		1NC+1NO 1NC+1NO	non	15°	75°
LHPE-18/2-R2-EX		2NC 2NC	non	15°	75°
LHP-10/4-R2-EX		2NC+2NO 2NC+2NO	not possible	30°	75°

Gold contacts: All above shown types are possible, the type figures change from 10 to 13 or from 18 to 19:

Use LHP..-13/... instead of LHP..-10/... for example LHPE-13/1-R-EX (1 NC + 1 NO, gold contacts)

Use LHP..-19/... instead of LHP..-18/... for example LHPE-19/2-R-EX (4 NC, contacts of gold)

Enclosure made of cast iron: Change type figures from old LHP.... to new LHM.... For example LHME-10/1-R-EX

Latching, manual reset: Is available for all types marked „non“ in the selection table. Use the „w“, for example LHPEw-13/1-R-EX or LHPw-10/3-R-EX

DITTELBACH UND KERZLER GmbH & Co. KG Talstrasse 27 D-35394 Giessen

Tel.: +49 641 97224-0 Fax: +49 641 97224-22 web: DUK.eu e-mail: info@DUK.eu